

Saffire LX-L & Saffire EVO LZ-L

Cylindrical latch 2-3/8" backset door preparation

NOTES:

1. USE DIMENSIONS FROM TABLE BELOW TO ADJUST BACKSET POSITION ACCORDING TO LOW AND HIGH BEVEL DOOR EDGE.
2. DIMENSIONS ARE SYMMETRICAL ABOUT ϕ UNLESS OTHERWISE NOTED.
3. REFER TO SPECIFIC TOLERANCES TABLE FOR DIMENSIONS MARKED WITH #.
4. DRAWING IS NOT TO SCALE.
5. DIMENSIONS ARE IN INCHES [mm].

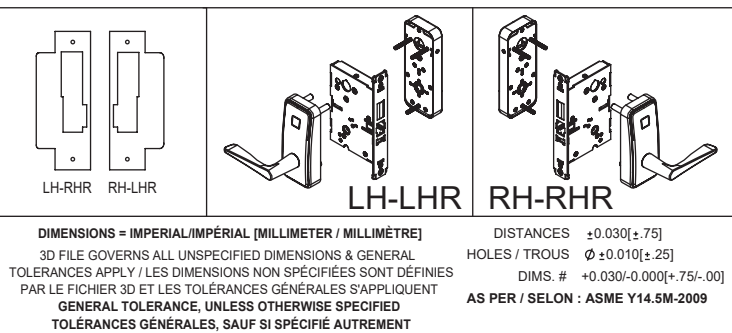
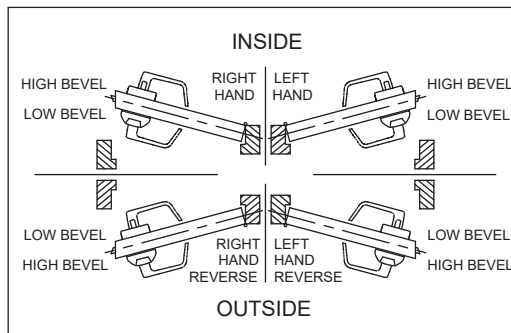
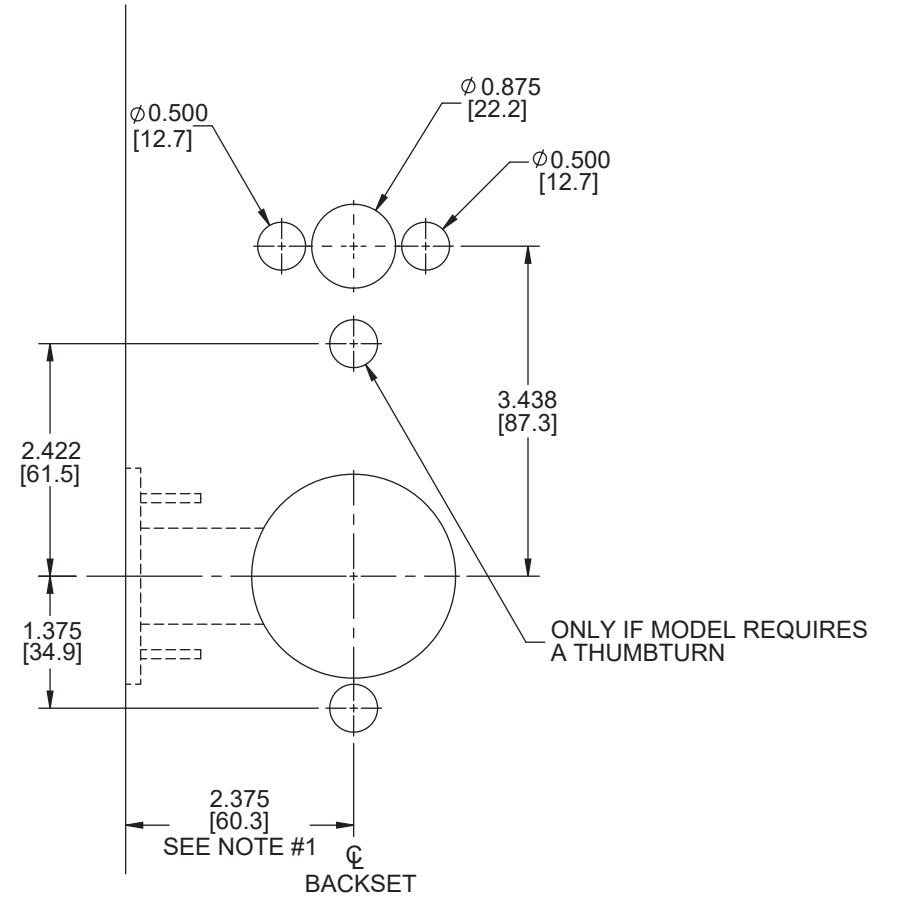
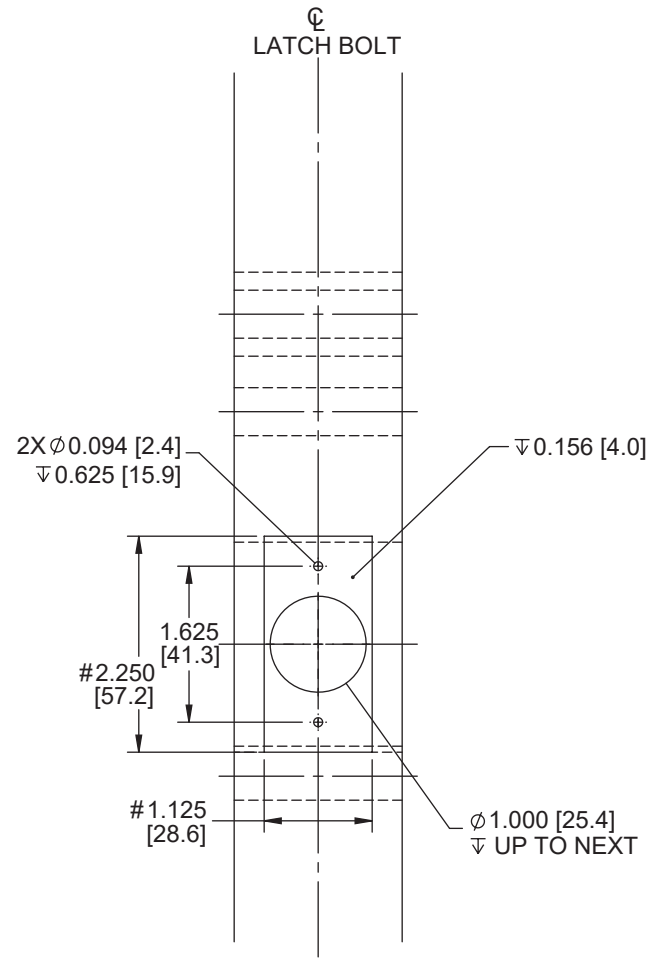
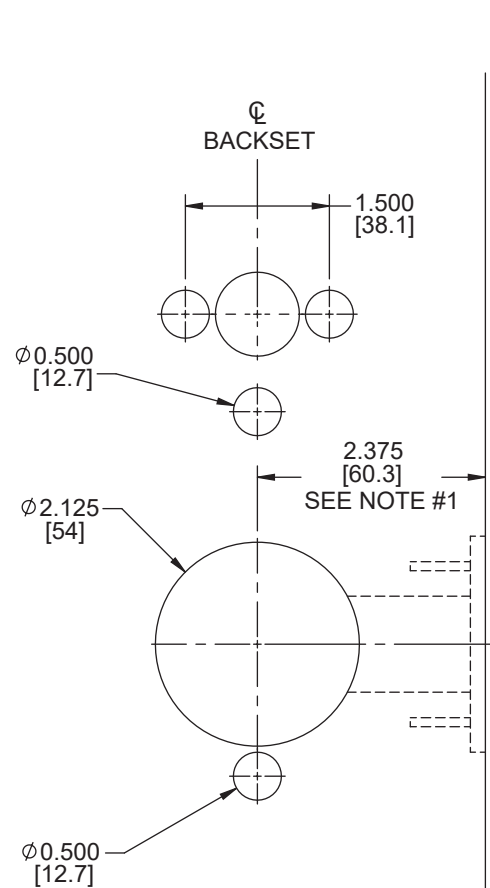
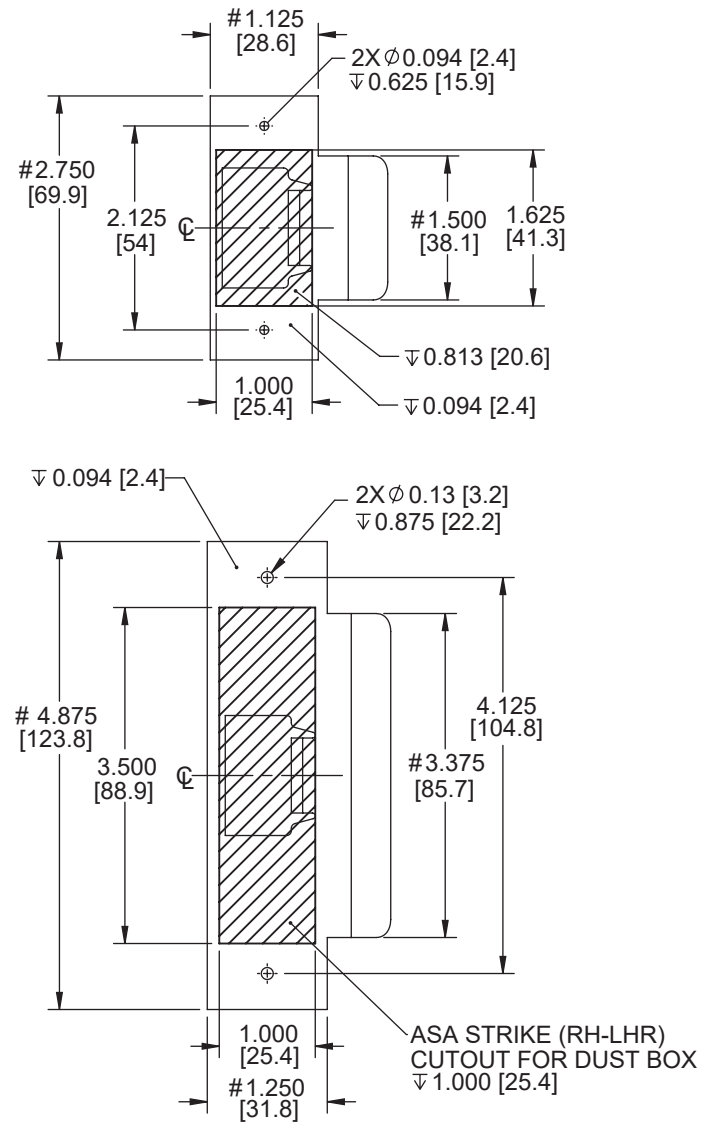

BACKSET ADJUSTMENT FOR 3° BEVEL DOOR		
DOOR THICKNESS DIMENSION X	BACKSET ADJUSTMENT DIMENSION Y	
1.25 [31.8]	0.032 [0.81]	
1.50 [38.1]	0.039 [1.00]	
1.75 [44.5]	0.046 [1.17]	
2.00 [50.8]	0.052 [1.32]	
2.25 [57.2]	0.059 [1.50]	
2.50 [63.5]	0.065 [1.65]	
2.75 [69.9]	0.072 [1.83]	

WARNING

- To verify lock coverage and door operation meets expectations, dormakaba strongly recommends completing a full door mockup. This will ensure that all necessary products and parts for a successful installation are included.
- Always validate that you have selected the correct template for specific lock model being installed. The same lock model can be offered with different locking device options.
- Drawing is not to scale. Measurements are for reference only. Not a drilling template.
- If you have any questions, please contact your local sales representative or authorized reseller.